



ProScreen, Inc.

Advanced Screen and Display Technologies

ProScreen Screen Systems and Accessories

Joseph Morgan, Phd
For Sales Orders call: (541) 779-7962

The ProScreen, Inc. Commitment

"Deliver a quality innovative projection screen with pride of craftsmanship,
at a fair price."

ProScreen Marketing Office
10 Crater Lake Avenue. Medford, OR. 97504. (541) 779-7962. Fax (541) 779-6959.



ProScreen, Inc.
Advanced Screen and Display Technologies

Video Projection Screens & Accessories

Current Products

INDEX	Product Summary	1
FRONT SCREENS		
VENUS ELECTRIC I		2-3
VENUS ELECTRIC I RF		4-5
MERCURY VIDEO WALL		6-7
GALAXY ELECTRIC II TRAP DOOR		8-9
SATURN ELECTRIC III		10-11
POLARIS ELECTRIC IV TAB TENSION TRAP DOOR		12
PRO DUPLEX		13-14
SOLAR MANUAL PULL DOWN		15
NEW! HIGH GAIN PROSCREEN PROSTAR SILVER SCREEN		16
RIGID DIFFUSION PROJECTION SCREEN		17
PROVISION REAR PROJECTION SCREENS		18
DNP PROSCREEN ALPHA REAR PROJECTION SCREENS		19
DNP PROSCREEN NEW WIDE ANGLE		20
DNP PROSCREEN GIANT REAR PROJECTION SCREENS		21
NEW! PROSCREEN PLASMAWALL		22-23
AIRSHOW by HOLOPROSCREEN		24-25
AIRSHOW DIGITAL SIGNAGE NETWORK SYSTEM		26
FABRICS AND FINISHES		27
PROSCREEN FABRICS		28
PROSCREEN RIGID SCREEN FRAMES		29
TERMS OF SALE		30

ProScreen, Inc.
Video Projection Front Screen Systems

Send Purchase Orders to Sales Office

10 Crater Lake Avenue. Medford, OR. 97504. (541) 779-7962. Fax (541) 779-6959.

International and 24 Hr. Fax (541) 779-6959.

Website <http://www.proscreeninc.com> E-mail info@proscreeninc.com

VENUS ELECTRIC I

VERSATILE PROJECTION SCREEN WITH ADVANCED DESIGN

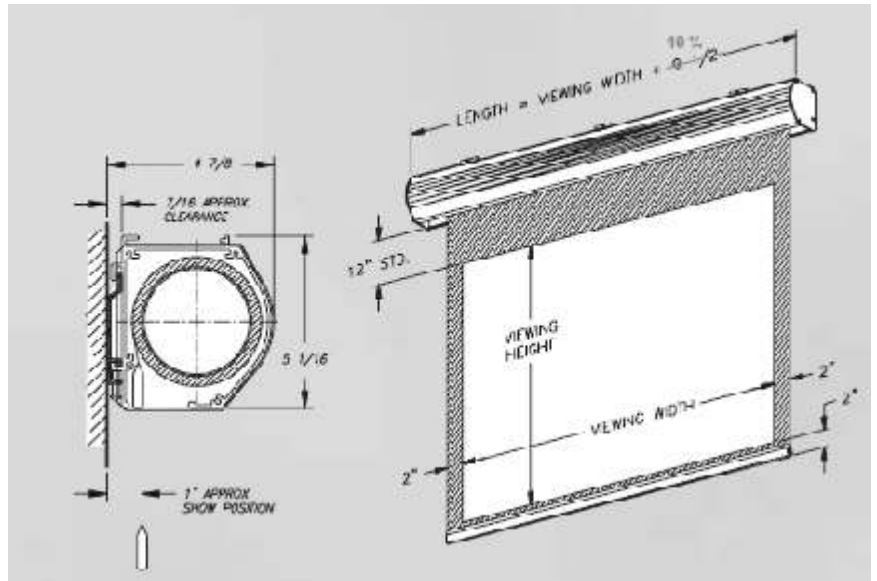

PROSCREEN'S MOUNTING AND INSTALLATIONS SYSTEM

ProScreen's mounting system has everyone in mind, especially the installer. The ProScreen mounting brackets are attached to studs wherever they may be. The screen housing has built in channels on the back and on the top in order to move the screen from side to side for best location. There is usually no need for two installer with ProScreen's design.

ELECTRIC I SCREEN DESIGN OFFERS MAXIMUM FLEXIBILITY & QUALITY

Ease of installation
 Seamless to 200" diagonal
 Adjustable mounting system
 Standard 2" black borders
 Custom orders our specialty

Quiet motor in roller design
 Optional infrared remote control or low voltage relay
 Standard 12" black leader
 Additional black leader available
 Choice of black, white or grey housing

Wall or ceiling mount. Heavy duty aluminum housing. Easy to install adjustable mount and quiet motor in roller design. Black, white or gray housing colors at no additional charge:

MATTE WHITE- industry standard fiberglass reinforced vinyl, seamless to 160"d- gain of 1.0

PRO-FLEX-PRO-heavy weight for perfect lay flat, seamless to 25'd-gain of 1.3

SOUND SCREEN-acoustically transparent, superior quality for center channel-gain of .85, for dim or dark rooms.

ProScreen, Inc. Video Projection Front Screen Systems

Send Purchase Orders to Sales Office

10 Crater Lake Avenue. Medford, OR. 97504. (541) 779-7962. Fax (541) 779-6959.

International and 24 Hr. Fax (541) 779-6959.

Website <http://www.proscreeninc.com> E-mail info@proscreeninc.com

VENUS ELECTRIC I RF

VERSATILE PROJECTION SCREEN WITH ADVANCED DESIGN

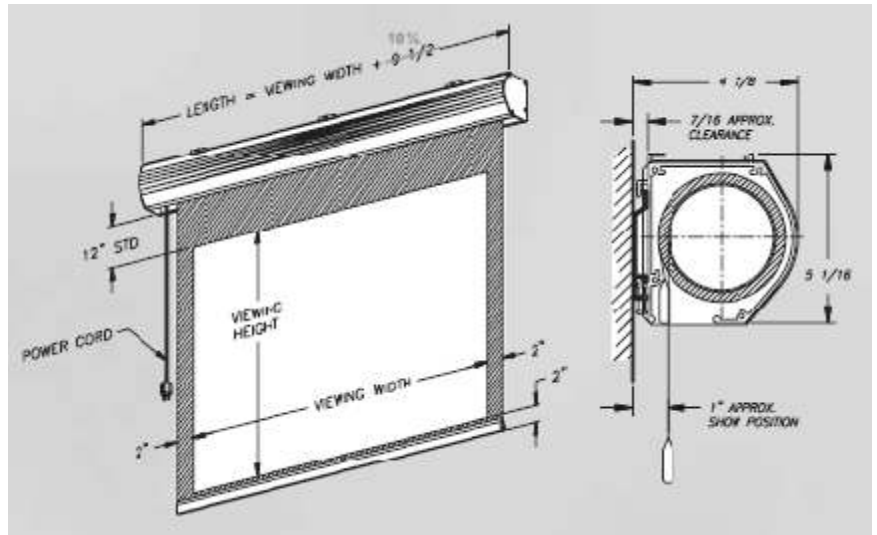

PROSCREEN'S MOUNTING AND INSTALLATIONS SYSTEM

ProScreen's mounting system has everyone in mind, especially the installer. The ProScreen mounting brackets are attached to studs wherever they may be. The screen housing has built in channels on the back and on the top in order to move the screen from side to side for best location. There is usually no need for two installer with ProScreen's design.

ELECTRIC I SCREEN DESIGN OFFERS MAXIMUM FLEXIBILITY & QUALITY

Motorized projection screen
 Built-in RF (Radio Frequency) remote control
 Dual wall or ceiling mount bracket system
 Quiet motor-in-roller
 Heavy duty aluminum housing

Choice of black, white or grey housing
 Self-supported fabrics only
 Comes standard with 12" black leader

Wall or ceiling mount. Heavy duty aluminum housing. Easy to install adjustable mount and quiet motor in roller design. Black, white or gray housing colors at no additional charge:

MATTE WHITE- industry standard fiberglass reinforced vinyl, seamless to 160"d- gain of 1.0

PRO-FLEX-PRO-heavy weight for perfect lay flat, seamless to 25'd-gain of 1.3

SOUND SCREEN-acoustically transparent, superior quality for center channel-gain of .85, for dim or dark rooms.

ProScreen, Inc.
Video Projection Front Screen Systems

Send Purchase Orders to Sales Office

10 Crater Lake Avenue. Medford, OR. 97504. (541) 779-7962. Fax (541) 779-6959.

International and 24 Hr. Fax (541) 779-6959.

Website <http://www.proscreeninc.com> E-mail info@proscreeninc.com

A9F7I FMJ-89C'G7F99BG
J9FG5H@'DFC>97HCB'G7F99B'K #K '58J5B798'89G, B

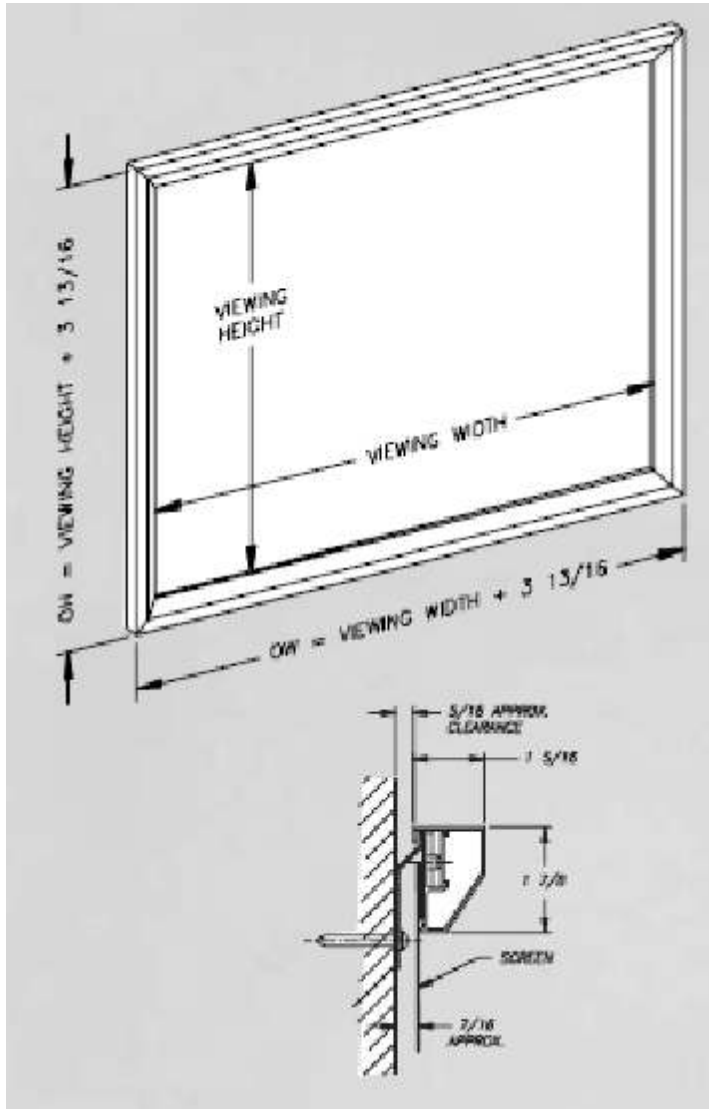

MERCURY FRONT VIDEO WALL SCREENS

DESIGNED FOR PERMANENT FLATNESS AND VERSATILITY

PROSCREENS MOUNTING AND INSTALLATION SYSTEM

ProScreen presents a tensioned screen with no snaps – a Velcro border for permanent tensioning! Clean sharp appearance...Can be installed on the wall or through the wall...Add optional legs and you have a portable screen. Truly a versatile design for use in homes, boardrooms, classrooms etc.

Available with:

- BriteWhite 1.5 Gain
- PearlBrite 3.1 Gain
- Rear View 2.5 Gain

A REAL INNOVATION IN THE DEVELOPMENT OF VIDEO PROJECTION SCREENS

Easy to install Standard and custom sizes available Black Velvet Frame available Durable black powder coated aluminum frames and hardware Fabrics to suit any installation Full 180 degree viewing on front surface Economical Rear View solution with wide viewing area Call or fax our sales department for assistance

ProScreen, Inc.
Video Projection Front Screen Systems

Send Purchase Orders to Sales Office

10 Crater Lake Avenue. Medford, OR. 97504. (541) 779-7962. Fax (541) 779-6959.

International and 24 Hr. Fax (541) 779-6959.

Website <http://www.proscreeninc.com> E-mail info@proscreeninc.com

GALAXY ELECTRIC II TRAP DOOR

THE ULTIMATE CEILING MOUNTED PROJECTION SCREEN

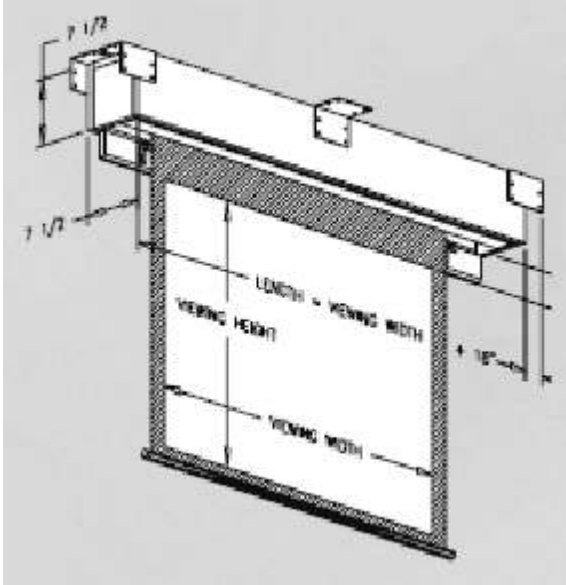

ELECTRIC II SCREEN DISAPPEARS INTO THE CEILING

Wood construction
 Seamless to 160" diagonal
 Optional formic finish
 Standard 2" black borders
 Flush Ceiling Mount with Automatic Trap Doors

Custom sizes are available
 Quiet motor in roller design
 Optional additional leader (drop)
 Optional perforated leader
 Optional infrared remote control or low voltage relay

Designed for flush ceiling mounting. Heavy duty wood composition housing with automatic trap door. Screen can disappear into the ceiling. Paint grade or mica (extra charge) doors. Quiet motor in roller. Choice of screen fabrics:

MATTE WHITE –fiberglass reinforced vinyl, seamless to 160" d-gain of 1.0

PRO-FLEX PRO- heavy weight for non-curl, perfect lay flat, seamless to 300" d-gain of 1.3

SOUND SCREEN-acoustically transparent, superior quality for center channel- gain of .85, for dim or dark room to 120" d

ProScreen, Inc.

Video Projection Front Screen Systems

Send Purchase Orders to Sales Office

10 Crater Lake Avenue. Medford, OR. 97504. (541) 779-7962. Fax (541) 779-6959.

International and 24 Hr. Fax (541) 779-6959.

Website <http://www.proscreeninc.com> E-mail info@proscreeninc.com

SATURN ELECTRIC III

TAB TENSIONED FOR FRONT OR REAR VIEWING SURFACES

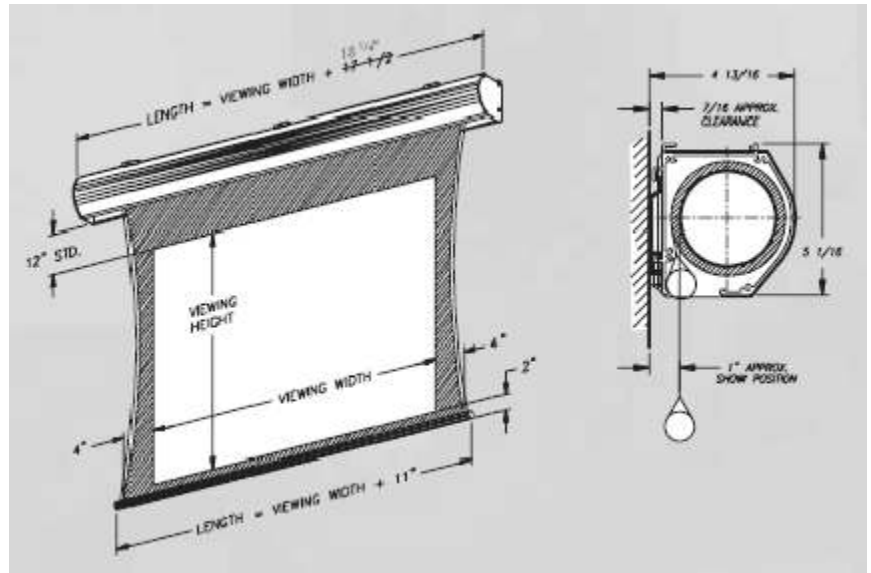

PROSCREEN'S MOUNTING AND INSTALLATIONS SYSTEM

ProScreen's mounting system has everyone in mind, especially the installer. The ProScreen mounting brackets are attached to studs wherever they may be. The screen housing has built in channels on the back and on the top in order to move the screen from side to side for best location. There is usually no need for two installers with ProScreen's design.

A RETRACTABLE SYSTEM THAT KEEPS UNSUPPORTED FABRICS PERFECTLY FLAT

- | | |
|---|--|
| Front View: BriteWhite 1.5 Gain / PearlWhite 3.1 gain | Custom orders are available |
| Rear view 2.5 gain | Quiet motor in roller design |
| Adjustable mounting system | Optional additional leader (drop) |
| Black, white or gray housing colors
(no additional charge) | Optional infrared remote control or low voltage
relay available |
| 3 Decorator panel inserts included | |

ProScreen, Inc. Video Projection Front Screen Systems

Send Purchase Orders to Sales Office

10 Crater Lake Avenue. Medford, OR. 97504. (541) 779-7962. Fax (541) 779-6959.

International and 24 Hr. Fax (541) 779-6959.

Website <http://www.proscreeninc.com> E-mail info@proscreeninc.com

POLARIS ELECTRIC IV TAB TENSION TRAP DOOR

TAB TENSIONED FOR REAR OF FRONT VIEWING CEILING MOUNT WITH AUTOMATIC TRAP DOOR

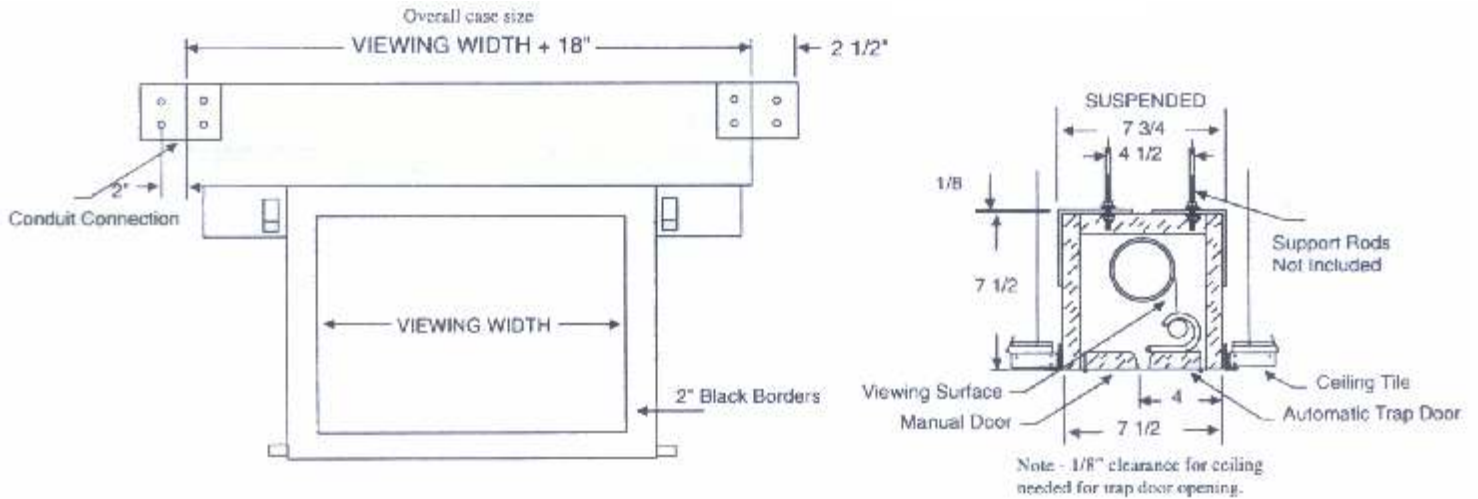

Polaris Electric IV is a retractable system for Rear View or higher gain Front projection. Heavy duty wood composite housing. Screen disappears into the flush ceiling mount. High gain fabrics are kept perfectly flat with tab tensioning. See page 4 for diagram of Polaris Electric IV.

ProScreen, Inc.
Video Projection Front Screen Systems

Send Purchase Orders to Sales Office

10 Crater Lake Avenue. Medford, OR. 97504. (541) 779-7962. Fax (541) 779-6959.

International and 24 Hr. Fax (541) 779-6959.

Website <http://www.proscreeninc.com> E-mail info@proscreeninc.com

PRO DUPLEX

RETRACTABLE FROM STANDARD TV TO WIDESCREEN WITH NO CHANGE IN FOCUS OR CONVERGENCE TRULY THE MOST ADVANCED PROJECTION SCREEN TODAY

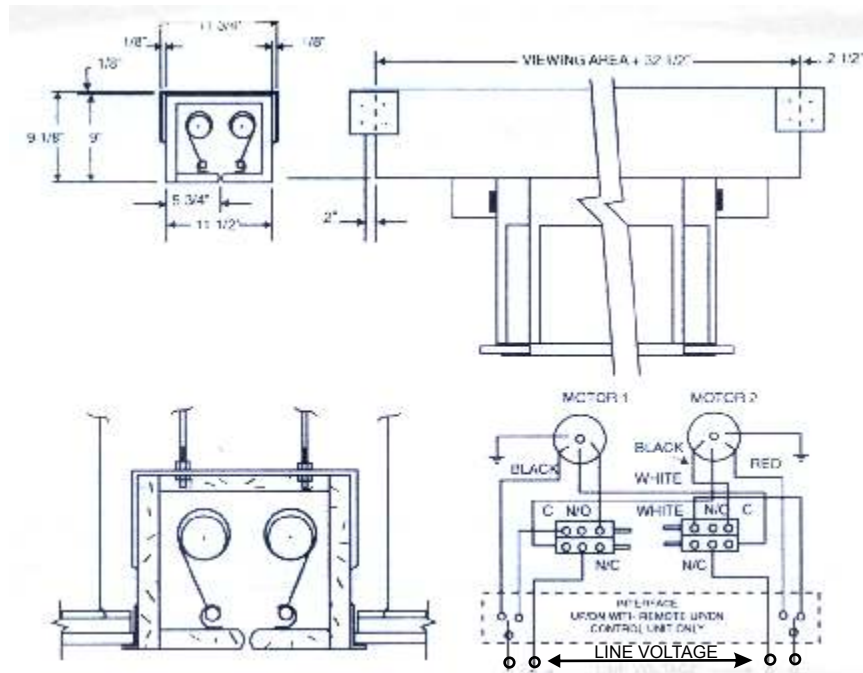

ProScreen PRO FABRIC is utilized in all duplex screens, assuring total flatness and curl free performance for years to come. The screen fabric is extremely durable and can be easily cleaned using recommended cleaners.

Sound screen fabric acoustically transparent, superior quality for center channel-gain of .85 for dim or dark room.

The screens are available in 4:3 / 16:9 and 4:3 / 1.85:1 aspects. Four standard sizes are available and custom sizes may be ordered.

BOTH SCREENS TRAVERSE IN THE SAME PLANE.

Both screens are operated with quiet motors in rollers which are electronically interlocked from simultaneous operation. The screens are controlled by ProScreen infrared remote control which features a two station transmitter, included in price. Automatic trap doors open and close when the screen is in use. When the screen is not in use the trap doors are closed into the ceiling. All of this is standard equipment with the "Duplex" model.

ProScreen, Inc. Video Projection Front Screen Systems

Send Purchase Orders to Sales Office

10 Crater Lake Avenue. Medford, OR. 97504. (541) 779-7962. Fax (541) 779-6959.

International and 24 Hr. Fax (541) 779-6959.

Website <http://www.proscreeninc.com> E-mail info@proscreeninc.com

GC @ F

'A5 BI 5 @F9HF57H56 @'DFC>97HCB'G7F99B

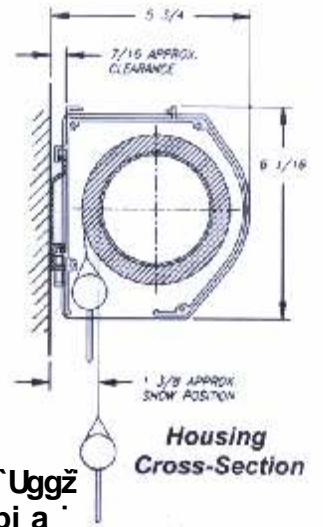
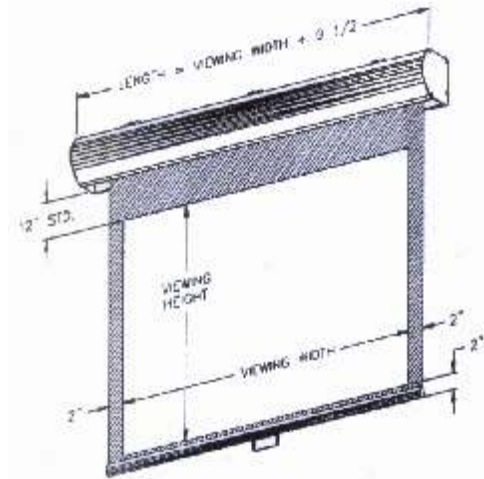

GC @ F]g'Uzcbhgi fZwY'dfc'Yw]cb'gWYYbza UXY'i d'cZa UHY'k\]h'zVYf[`Uggz
fY]bZcfWYX'j]bm'UbX'a Ubi U'mfYfUWYX']bhc'U\ YUj mXi hmcby!d]Yw'U i a]bi a
\ ci g]b["H]g'gWYYb'Wta Yg'k]h' 'UW c]w'cZXYWcfUrcf'cf'd'U]b'dUbYg"



HIGH GAIN PROSCREEN PROSTAR SILVER SCREEN FRONT SCREEN

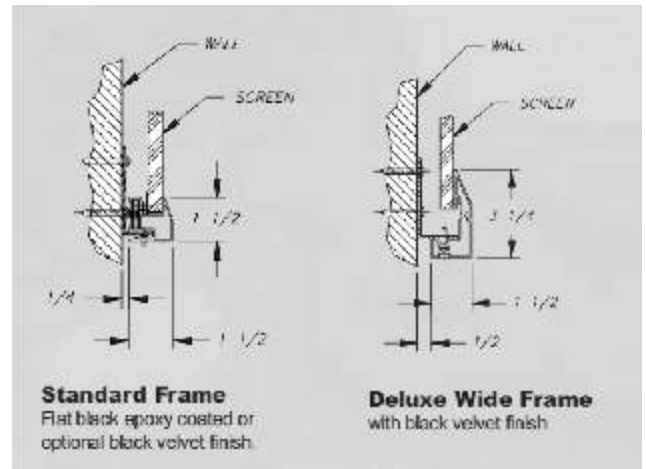

(The First NEW Front Projection Screen Technology In 25 Years!)

Flat front projection screen that achieves high gain, high contrast and color purity in ambient light

- High gain (6.0)
- High contrast
- Light control is not critical
- Wide viewing area
- Outstanding color reproduction "No Color Shift"
- Panels can be multiplexed for large presentations
- Screen is fully assembled and shipped in wood crate
- Optional black velvet finished frame*

A flat front projection screen that achieves higher gain (6.0), high contrast, and color purity in ambient light. Picture detail jumps out at you. With this type of performance, there is no need to reduce brightness to achieve both high contrast and high black levels. SilverStar is applicable to home-theater, media-room and commercial applications such as trade shows, visual merchandising information, museum displays, educational and virtually unlimited display applications.

ProScreen, Inc. **Video Projection Front Screen Systems**

Send Purchase Orders to Sales Office

10 Crater Lake Avenue. Medford, OR. 97504. (541) 779-7962. Fax (541) 779-6959.

International and 24 Hr. Fax (541) 779-6959.

Website <http://www.proscreeninc.com> E-mail info@proscreeninc.com

RIGID DIFFUSION REAR PROJECTION SCREEN LARGE, SINGLE AND MULTI-DISPLAY

NOTE: Call for freight cost estimates for destination delivery. ProScreens are priced per square footage of their overall size substrate. To calculate square footage, use overall size dimensions only and round to two decimal places.

Gains of 1.0, 1.5, 2.0 and 2.5 available upon request. High Contrast (HC), Dark Gray, Neutral Gray and White coatings, no extra charge.

COATING NOTE: ProShield add 20% per square foot. ProShield is a hard coat, write-on surface, coated on audience side. All standard coatings

have a built-in abrasive resistant surface at no additional charge.

Non-glare coating, add 15% per square foot for opposite side coating. This is a dry marker write-on surface. Hard-coating add 20% per square foot for opposite side coating. This is a dry marker write-on surface.

BUTT EDGES: When a multiple screen installation is chosen and it is required that the surface butt edges be ground and polished, this is a special process. Please contact our sales department for quotes on this process cost. We do CNC cutting and routing.



DNP PROSCREEN ALPHA REAR PROJECTION SCREENS

MULTI-PURPOSE REAR SCREENS



The dnp Alpha Screen is a multi-purpose screen for all rear projection applications, which require a combination of wide viewing angles – both horizontally and vertically – enhanced contrast, brightness uniformity and high resolution. This makes the Alpha Screen ideal for modern conference rooms and control room environments. The excellent vertical viewing angles also make the Alpha Screen well suited for multi-screen installations. The Alpha Screen is an advanced optical micro filter screen. Due to the special construction of the Alpha Screen it offers infinite resolution. Furthermore, the screen has an anti-glare front surface to minimize reflections from windows and room lighting. The Alpha Screen is especially developed for the new generation of powerful single-lens projectors. Due to their brightness, these projectors require a screen with the ability to distribute the brightness evenly – and to enhance the perceived contrast of the image. The Alpha Screen fulfills both needs.

The Alpha Screen offers perfectly symmetrical viewing angles – both vertically and horizontally.

The high precision Fresnel lens on the projector side redirects the projected light and sends it forwards at right-angles to the screen. The built-in optical micro filter, comprising high-refractive particles, distributes the light forward and generates a perfectly symmetrical viewing cone.

- Wide vertical and horizontal viewing angles
- High contrast
- Infinite resolution
- Multiple options for focal length
- Easy-clean surface
- Compatible with LCD, DLP, LCOS, Light Valve and D-ILA projectors

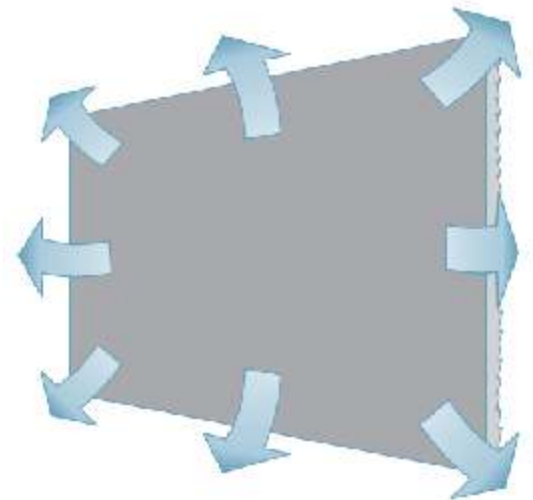

ProScreen, Inc.

Video Projection Rear Screen Systems

Send Purchase Orders to Sales Office

10 Crater Lake Avenue. Medford, OR. 97504. (541) 779-7962. Fax (541) 779-6959.

International and 24 Hr. Fax (541) 732-0858.

Website <http://www.proscreeninc.com> E-mail info@proscreeninc.com

DNP PROSCREEN NEW WIDE ANGLE REAR PROJECTION SCREENS

The dnp New Wide Angle Screens (NWA) are a unique range of screens within the dnp Wide Angle Screen family – the world's best selling optical ProScreen screens for professional installations. The NWA Screen can be used in practically every ProScreen application you can think of – plus a few others!

The NWA Screen offers true 180° horizontal viewing angles, high contrast and ultra-fine resolution and has a special dark tint, which enhances the contrast. The NWA Screen is especially designed for single lens projectors (LCD, DLP etc.), which are very bright but many of which have relatively poor contrast. The NWA Screen has been optimized for these projectors to give excellent black levels, good contrast and color saturation. The NWA Screen is an optical single element system with 2 active lens surfaces. The screen features a special dark tint which enhances the contrast and color depth of the image. The screen produces an optimum viewing area which is very wide horizontally and relatively narrow vertically.

- Improved Wide Angle lens technology
- Enhanced resolution
- 180° horizontal viewing angle
- High image brightness
- Multiple options for focal length
- Compatible with LCD, DLP, Light Valve, LCOS and D-ILA projectors

The high precision Fresnel lens on the projector side redirects the projected light and sends it forwards at right angles to the screen. The diffusion material in the acrylic screen controls the vertical light distribution. The fine pitch lenticular lens on the front side of the screen distribute the image through a 180° horizontal viewing area.

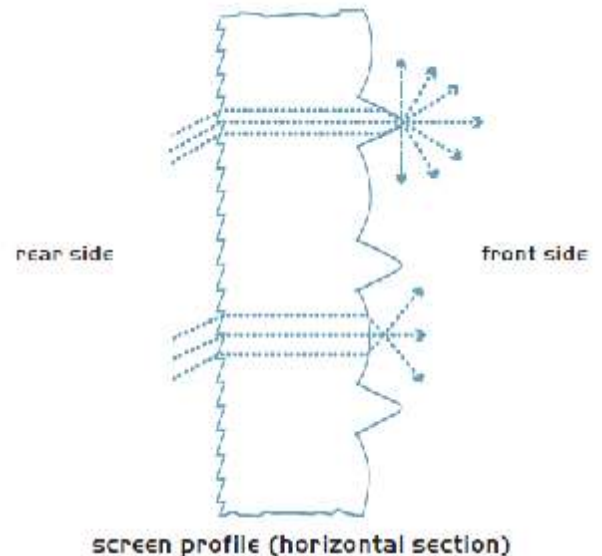

ProScreen, Inc. Video Projection Rear Screen Systems

Send Purchase Orders to Sales Office

10 Crater Lake Avenue. Medford, OR. 97504. (541) 779-7962. Fax (541) 779-6959.

International and 24 Hr. Fax (541) 732-0858.

Website <http://www.proscreeninc.com> E-mail info@proscreeninc.com

DNP PROSCREEN GIANT REAR PROJECTION SCREENS

The dnp ProScreen Giant Wide Angle (GWA) is a series of large screens including the world's first 200" optical rear projection screen. With an image area up to 4 x 3 metres, the GWA Screen offers the size of a 5 x 5 40" cube video wall – but in a single screen! This makes the screen well suited for projection of large high-quality images in conference and control rooms with long viewing distances. The GWA Screen is designed especially for projection to large audiences and produces bright, sharp images over a broad viewing area. The GWA Screen is a single element optical system with two active lens surfaces. Due to its optical lens design, the dnp GWA Screen offers very good brightness uniformity and contrast levels. GWA Screens are available in sizes from 140" – 200" in 4:3 format. On request the screens can be cut down to 16:9 widescreen format up to 180". Screens in sizes from 140" – 160" can be ordered ready-mounted in the frame system to make installation easier. A special rigid 40 x 40 mm square aluminum frame is available for screens in size range 161" – 200". The screen is pre-fitted with the frame's top section for easy removal from the crate. This special framing system is supplied as standard with all screens from 161" – 200".

- Optical Fresnel lens system
- High image brightness
- Screen sizes from 140" – 200"
- Available in 16:9 wide screen format up to 180"
- Compatible with LCD, DLP, LCOS, Light Valve and D-ILA projectors

The high precision Fresnel lens on the projector side redirects the projected light and sends it forwards at right angles to the screen. The diffusion material in the acrylic screen controls the vertical light distribution. The fine pitch lenticular lens on the front side of the screen distribute the image through a 180° horizontal viewing area.

FRAMES ARE INCLUDED IN GIANT SCREEN PRICING
See page 27

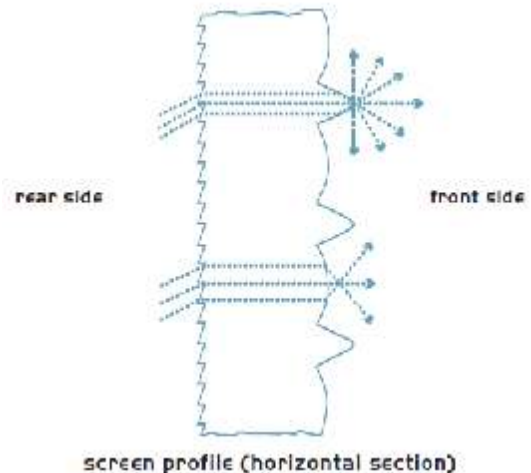

ProScreen, Inc. Video Projection Rear Screen Systems

Send Purchase Orders to Sales Office

10 Crater Lake Avenue. Medford, OR. 97504. (541) 779-7962. Fax (541) 779-6959.

International and 24 Hr. Fax (541) 779-6959

Website <http://www.proscreeninc.com> E-mail info@proscreeninc.com

PROSCREEN PLASMAWALL

TECHNOLOGICAL DISPLAY SOLUTIONS FOR VISUAL MERCHANDISING

Infinitely expandable Multi-PDP

4 sides DZF technology implement seamless Multi-PDP

4 side DZF(dead zone free) , makes the edge of each panel luminant.

It gives an excellence in continuity of displays with less than 2.2mm seam when consisting video-wall and improves the uniformity

Remarkably with 4-sides glass edge structure technology.

The newly developed edge structure allows for impressive reduction of gap between each panel.

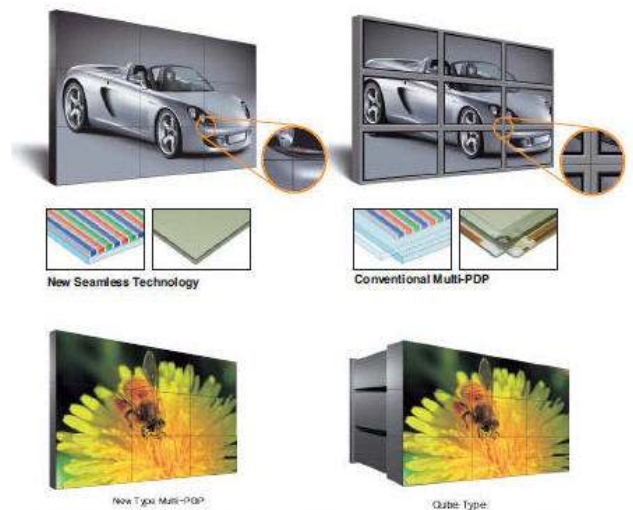

ProScreen, Inc. Video Projection Rear Screen Systems

Send Purchase Orders to Sales Office

10 Crater Lake Avenue. Medford, OR. 97504. (541) 779-7962. Fax (541) 779-6959.

International and 24 Hr. Fax (541) 779-6959.

Website <http://www.proscreeninc.com> E-mail info@proscreeninc.com

PROSCREEN PLASMAWALL
TECHNOLOGICAL DISPLAY SOLUTIONS FOR VISUAL MERCHANDISING

Infinitely expandable Multi-PDP



Video Wall



Signage

**Contact us for
 more
 information!**

541-779-7962

Complete Specifications

screen size 42"
 dimensions
 36.46" x 320.59" x 3.01"

display area
 36.26" x 20.39"

aspect ratio 16 : 9

pixel resolution 853 x 480

peak brightness [w/o film]
 1000 cd/m²

contrast ratio [dark room]
 3000 : 1

screen size [h x v]
 36.26" x 20.39"

displayable colors
 16.7 million

cell pitch [h x v]
 1.08 x 1.08 mm

color temperature
 3200 k | 6500 k | 9300 k

view angle > 160 degree

technology
 DZF technology plasma panel

description
 42" M-PDP, plasma video wall

seam gap [multi formation]
 > 2.2 mm

formation of video wall
 multi screen [m x n]

weight
 25 kg | 59.5 lbs

power consumption
 360 W [max]

front panel controls
 n/a

display formats
 multi screen | multi input
 display | mono screen

pc formats
 VGA | SVGA | XGA | SXGA
 [650 x 350 ~ 1600 x 1200]

RS-232C
 straight cable [2, 3, 5] 9600 ~
 115200 BPS

PC control [included]
 drag & drop, scenario
 generator, image adjustments,
 control up to 16 units

user programmable
 control up to 254 panels

input voltage
 100 vac~ 240 vac | 50/60Hz |
 auto selection

others
 NTSC | JPAL | SECAM, digital
 comb filter, film|video mode,
 edge smooth, motion adaptive
 de-interface, noise reduction

accessories
 mount fixtures, video
 processors, switchers, wi-
 fi/tcp/ip data/image
 trasmitters, 3d
 autosetretroscope, digital
 signnage management
 systems

analog RGB
 1/1 D-sub 15pin / PC

component
 1/1 Y,Cb | PB, Cr | Pr - BNC
 type

composite
 1/1 CVBS - BNC type

Y/C [s-video]
 1/1 4-pin mini din

DVI-D
 1/1TMDS 24pin

remote control
 1/1 RS232 D-sub 9pin

ProScreen, Inc.
Video Projection Rear Screen Systems

Send Purchase Orders to Sales Office

10 Crater Lake Avenue. Medford, OR. 97504. (541) 779-7962. Fax (541) 779-6959.

International and 24 Hr. Fax (541) 779-6959.

Website <http://www.proscreeninc.com> E-mail info@proscreeninc.com

AIRSHOW by HOLOPROSCREEN FOR VISUAL MERCHANDISING

SIGNAGE SIZZLE

AIRSHOW replaces traditional 4'x 8' static flat panel graphics window display signage with a 40" or 60" diagonal transparent visual active screen on acrylic panels.

AIRSHOW attracts a crowd to your window with eye catching, moving visual merchandising images projected on see-through acrylic or on-glass store fronts.

The AIRSHOW is Transparent!

You can see through the acrylic sheet to the store merchandise, yet view your full bright foreground production content on the screen.

Why is the AIRSHOW Transparent?

The customers can see into the retail store and the sales associate can see the customers. AirSho hangs on thin cable from the ceiling store windows.

The photo-optic film refracts only the projected light from a LCD projector at a 35° angle. All other light is rejected, so only your message is seen by the customer.

Frequently Asked Questions

• What is the AIRSHOW made of?

A special resin called a Photopolymer Film.

• How does it work?

The special resin refracts light like a prism so that it emerges from the front of the screen, producing a bright and clear image.

• Can it be seen in bright sunlight?

Yes! The Photopolymer Optic Film does not reflect sunlight, but transmits polarized images from the projector to the front of the screen so the images can be seen from outdoors under bright or sunny conditions.

• What sizes is it available in?

40" and 60" diagonal screens are now available. Larger sizes are pending.

• What applications can it be used for?

Department stores, shopping malls, car dealerships, travel agencies, museums, banks, securities companies, ticket offices, airports, rail stations, restaurants. Virtually any public place.

Increase foot traffic... Increase revenue

35% more customers enter retail stores with moving visual images, creating impulse purchases.

10% revenue increase as a result of traffic increase.

Digital Signage Content

The highest customer attraction and retention rates are maximized by flashing text, flying and fading transition and features such as 3-D effects and constantly changing video clips.

Generate Revenue by Selling AD Space

Use your air space to generate revenue with the AIRSHOW

Vendors pay for extra ad space. Along with SQ footage floor revenue, use the air space above your floor to compound your return.

AIRSHOW by PROSCREEN Will Optimize Your Business

Increase sales through dynamic 3-D digital ads • Generate added revenue by selling ad space • System design and installation • Build brand awareness • Update content centrally or locally React quickly to competitive price changes and merchandising feature changes.



ProScreen, Inc. Video Projection Rear Screen Systems

Send Purchase Orders to Sales Office

10 Crater Lake Avenue. Medford, OR. 97504. (541) 779-7962. Fax (541) 779-6959.

International and 24 Hr. Fax (541) 779-6959.

Website <http://www.proscreeninc.com> E-mail info@proscreeninc.com

AIRSHOW by HOLOPROSCREEN

DIGITAL SIGNAGE NETWORK SYSTEM FOR VISUAL MERCHANDISING

Now you can control the most advanced Digital Signage Interface from a single location.

- Retail Visual Merchandising Signage,
- Displays, Exhibits
- Create and Control from a single PC
- Publish Internally, Externally or both
- Publish fresh content to hundreds of displays in real time
- Utilize our Show Stopping AIRSHOW by HoloProscreen for a Significant "Wow Factor" to build retail traffic and profitability



ProScreen Digital Signage Example 6 HoloProScreens

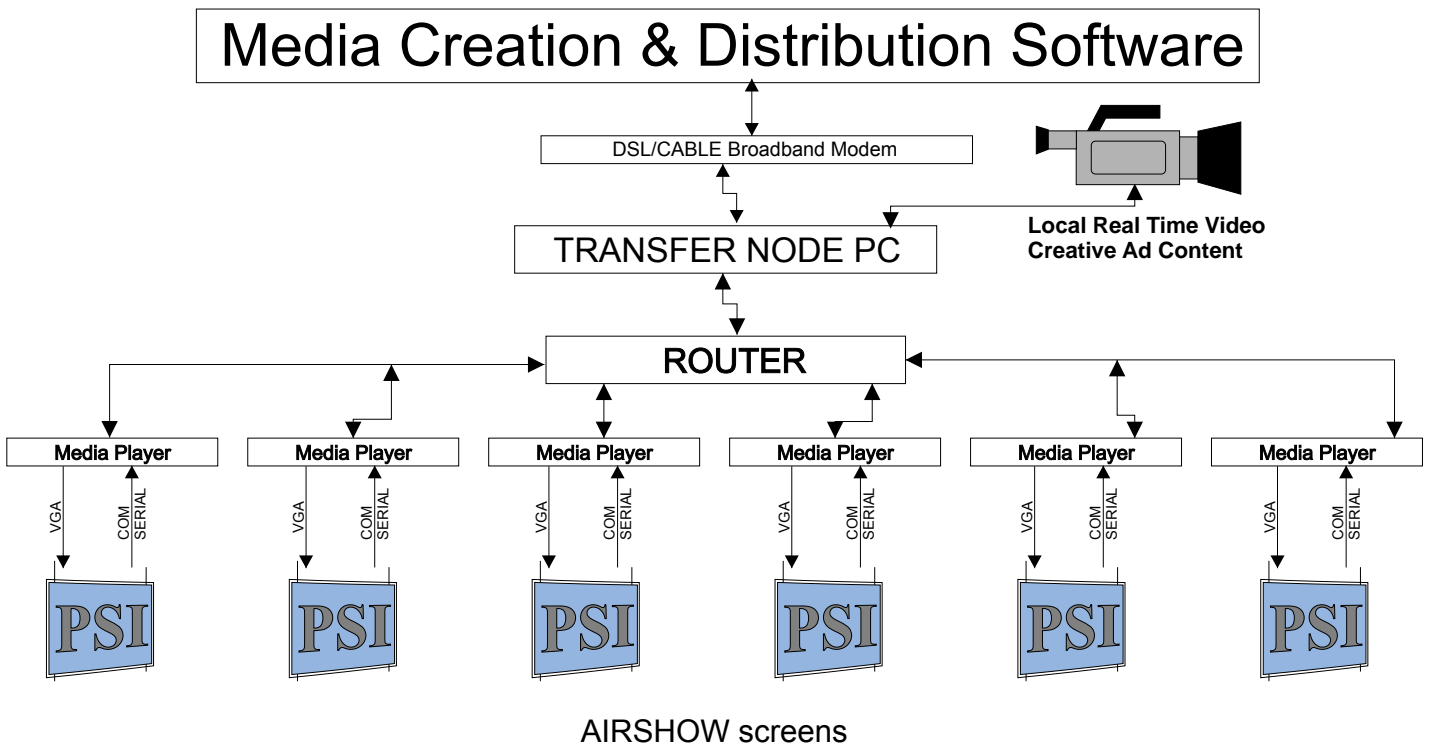

ProScreen, Inc.
Video Projection Front and Rear Screen Systems

Send Purchase Orders to Sales Office
 10 Crater Lake Avenue. Medford, OR. 97504. (541) 779-7962. Fax (541) 779-6959.
 International and 24 Hr. Fax (541) 732-0858.
 Website <http://www.proscreeninc.com> E-mail info@proscreeninc.com

PROSCREEN FABRICS AND FINISHES

PROSCREEN CURVED SCREEN ULTRA HIGH GAIN ALUMINUM FOIL: Used on all models of ProScreen Ultra High Gain Curved Screens. Carefully developed and improved over many years to achieve maximum gain of 13.2" at zero degree and to maximize breadth of viewing area. Truly the world's brightest front view screen material.

PROSCREEN MATTE WHITE: Standard pure white fiberglass reinforced Vinyl with a BLACK OUT BACK. Excellent performances in a moderately priced fabric. Seamless to 160" diagonal. 1.0 Gain, 160 degree viewing cone.

PROSCREEN PROFLEX: ProScreen sets a new standard for screen fabric. Finest matte white coated fabric is heavy weight (36 oz/sq yd) and semi-rigid.

Seamless up to 28 feet diagonal. Absolute lay flat and curl-free characteristics.
1.3 Gain, 160 degree viewing cone. Optional black out black (*)

SILVER LENTICULAR: A bright (2.6 gain) self-supporting fabric for screens up to 72" wide. Can be used in Venus Electric I and Galaxy Electric II for difficult lighting situations.

PEARL MATTE: ProScreen's newest fabric for Venus Electric I, Galaxy Electric II and Solar Manual screens. For ambient light situations that require higher gain screen fabrics. Reinforced vinyl with a black out back. Gain 2.8 at center axis with 1.5 gain at 45 degree. 72" maximum height.

BRITE WHITE: ProScreen's unsupported Brite White fabric has a gain of 1.5. A reflective coating adds brightness without hot spotting. Available in Mercury Framed Screens and Saturn Electric III models. This material must be under tension. Screen heights up to 108" can be accommodated. 104 degree viewing cone. Optional black out black (*)

PEARLBRITE: At 3.1 gain, the brightest flat screen fabric available. This is an excellent fabric for LCD projection or for CRT projection where ambient light is controlled. Must be installed under tension in either Saturn Electric III or Mercury Framed models. Optional black out back (*)

PROSCREEN REAR VIEW: Excellent flexible Rear View material. Gain of 2.5 with excellent ambient light rejection. Available in Saturn Electric III and Mercury Framed models. Must be under tab tension.

PROSCREEN RIGID DIFFUSION SCREENS: Offering a high performing diffusion coating for rigid rear view screens. Gain and contrast of coating, ranging from 1.0 to 2.5, can be specified. A second Techshield write-on surface is available. Either a glass or acrylic substrate can be used. (See Rear Screen Catalog)

ProScreen DNP OPTICAL/LENTICULAR: A cast acrylic fresnel/lenticular Lens rigid rear view screen that provides a viewing cone in bright ambient light with gain of 5.0. (See Rear Screen Catalog)

Optional BLACKOUT BACK available. Contact sales office for pricing.

ProScreen, Inc.

Video Projection Front and Rear Screen Systems

Send Purchase Orders to Sales Office

10 Crater Lake Avenue. Medford, OR. 97504. (541) 779-7962. Fax (541) 779-6959.

International and 24 Hr. Fax (541) 732-0858.

Website <http://www.proscreeninc.com> E-mail info@proscreeninc.com

PROSCREEN RIGID SCREEN FRAMES

The unique feature of the dnp Proscreen Rigid Frames system is the flexible suspension system built into the frame. This advanced spring system prevents screen warping as it allows the screens to adjust and adapt to changes in both temperature and humidity. The special spring system also secures that the screens are kept together with an image-to-image separation of less than 0.3 mm. Unlike most "seamless" screen systems on the market, the dnp Proscreen Rigid Frames system has no visible T-profiles! Furthermore, the dnp Proscreen Rigid Frames system features integrated baffles between each screen. This prevents light from one projector affecting the next screen – and makes projector adjustments easier.

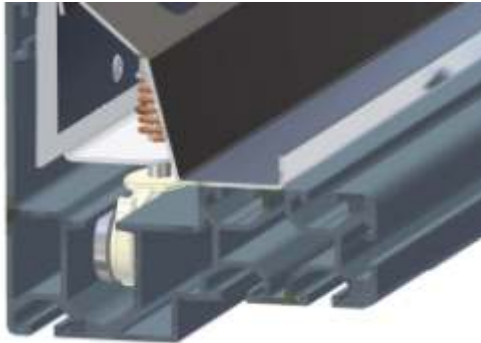

The built-in spring system prevents screen warping and reduces the gap between the images to less than 0.3 mm.



The dnp Proscreen Rigid Frame is delivered as a pre-mounted system ready to install.



The standard mounting option.



The flush mounting option.

ProScreen, Inc.

Video Projection Front and Rear Screen Systems

Send Purchase Orders to Sales Office

10 Crater Lake Avenue. Medford, OR. 97504. (541) 779-7962. Fax (541) 779-6959.

International and 24 Hr. Fax (541) 779-6959.

Website <http://www.proscreeninc.com> E-mail info@proscreeninc.com

PROSCREEN TERMS OF SALE

- High quality ProScreen products
- Fast delivery and service
- Fair prices always

1. ProScreen sells to only authorized ProScreen dealers under this product catalog. Possession of this catalog does not constitute an offer to sell.
2. All prices are FOB Factory U.S.A., and subject to change without notice.
3. Payment terms: Net 30 days from invoice with approved credit or use your Visa or MasterCard.
4. Some product require special crating related charges. Please confirm at time of order placement.
5. Inspection policy: All products shipped by ProScreen must be inspected no later than 5 days after arrival. ProScreen will not accept claims after this time. Any damage must be reported to the delivering carrier and ProScreen immediately.
6. Return policy: No product may be returned without ProScreen prior approval. Returns will be subject to restocking charges and must be shipped pre-paid.
7. All product shipped via UPS or common carrier unless otherwise advised. Certain product requires more than one crate, which affects shipping costs. All shipments are shipped collect or pre-paid and billed to dealer per agreement upon receipt of purchase order.
8. ProScreen will insure all shipments unless otherwise advised. 2% will be added to your invoice for this service. If you have freight damaged ProScreen products on an insured shipment and you have reported this damage to the delivering carrier within 5 days of receipt, ProScreen will replace the ProScreen product and assume responsibility for collecting from the carrier, when received, issue you a 100% credit. If shipment is not insured, ProScreen will not be responsible for freight damage or collection of any and all claims.
9. Limited warranty: ProScreen warranty covers defects in material and workmanship for a period of one year from the date of shipment.

ALL PRICES ARE FOB FACTORY
All Screens are shipped in wood crates.



ProScreen, Inc. Video Projection Front and Rear Screen Systems

Send Purchase Orders to Sales Office

10 Crater Lake Avenue. Medford, OR. 97504. (541) 779-7962. Fax (541) 779-6959.

International and 24 Hr. Fax (541) 732-0858.

Website <http://www.proscreeninc.com> E-mail info@proscreeninc.com